

LC-1000 Lube System Controller

DESCRIPTION

The Trabon microprocessor based LC-1000 Controller is a multi-use solid state controller that is dedicated to the operation and monitoring of intermittent operating series and parallel centralized lubrication systems equipped with a cycle or pressure switch for cycle completion feed back.

The LC-1000 monitors and schedules lubrication intervals in either time or stroke/cycle basis in values ranging from 1 to 9999. Pump may be self cycling or single cycle type requiring a pulsed output.

Four units are available for 12 VDC, 24 VDC, 115 VAC, or 230 VAC operation. The LC-1000 is easy to program in the field using four mini push-buttons. The programming requires no special knowledge or training of computer language. During power down or outage, all data is saved in EEPROM (Electrically Erasable Programming Read Only Memory). As power is restored, counting and pump status are restored to values prior to the loss of power.



SPECIFICATIONS	
Power Supply	115 VAC \pm 10%, 50/60 Hz, 1 ph; 230 VAC \pm 10%, 50/60 Hz, 1 ph; 12 VDC \pm 10%; 24 VDC \pm 10%
Output Loading	
Main Pump Load	12 VDC-230 VAC, 50/60 Hz, 10 amp replay output (external fused by user)
Fault Output Signal	12 VDC-230 VAC, 50/60 Hz, 1 amp resistive max (N.O.) dry isolated contact (external fused by user)
Temperature Range	Do Not Locate Unit in Direct Sunlight
Operating	-4°F to 122°F (-20°C to 50°C)
Storage	-13°F to 140°F (-25°C to 60°C)
Enclosure	Plastic with Clear Cover, NEMA 4X, IP 66
Display	Supertwist LDC, Annotated 4 Digit, 4 LED's - PWR (GN), LUBE (YW), FAULT (RD), CYCLE (YW)
Stroke Input	
Max Input Rate	10 Hz (600 cpm)
Nominal 12 Volts	12 VDC version
Nominal 24 Volts	24 VDC, 115 VAC, 230 VAC versions
Other Inputs	
Cycle Switch	12 Volts, dry contact, 2.5 mA max, counts half cycles

Programming Selection	
Output On	1-9999 sec, min, hrs, counts
Output Off	1-9999 sec, min, hrs, counts
Cycle Counter	Half counts (0-99)
Pump	Steady State or Pulsed
Pulse Off Time (Prime)	3 sec fixed
Pulse On Programmable	0-99 sec
Program Entry	4 Mini Push Buttons - Program, Increase, Shift, Enter
EEPROM	Electrically Erasable Programming Read Only Memory

WIRING INFORMATION

Option for units built after February 1, 1999 that are programmed in time mode.

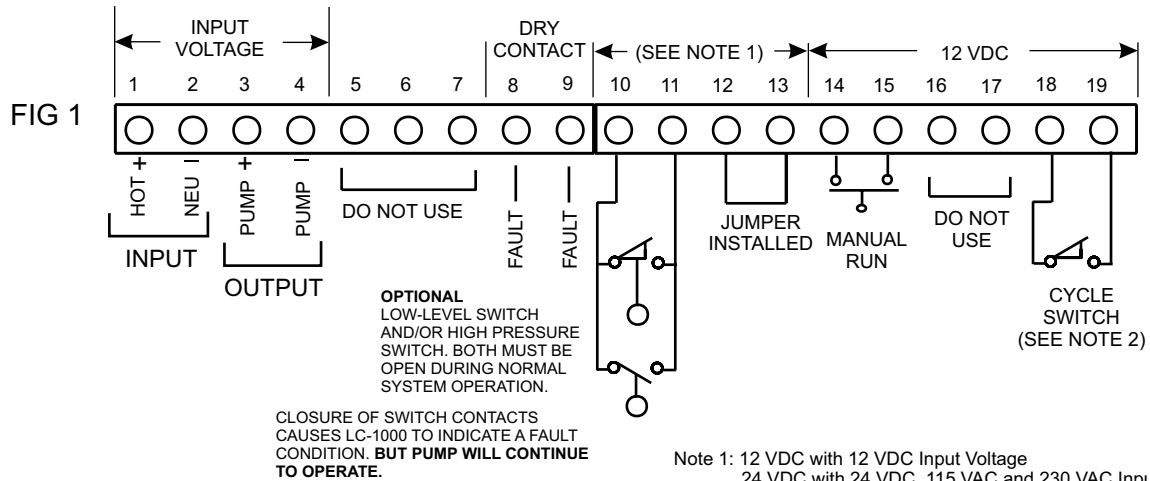

WIRING INFORMATION

All units programmed in machine count mode, or any units built prior to February 1, 1999.

Option for units built after February 1, 1999 that are programmed in time mode.

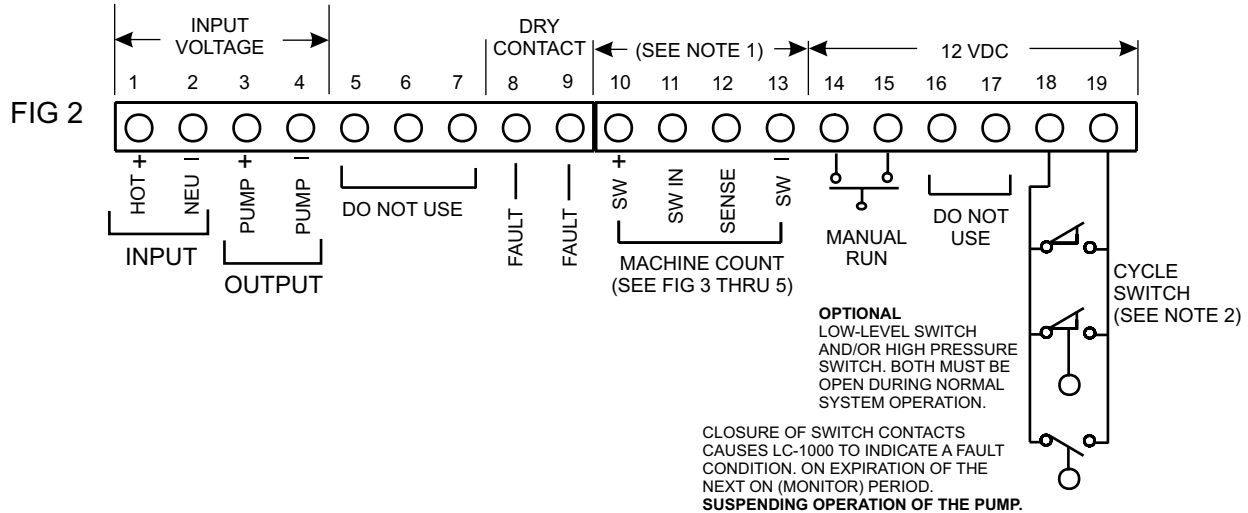
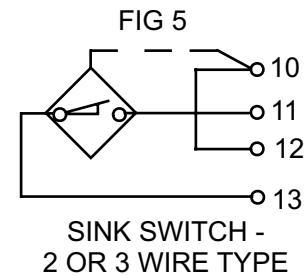
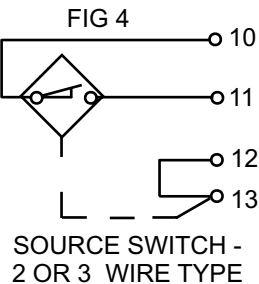
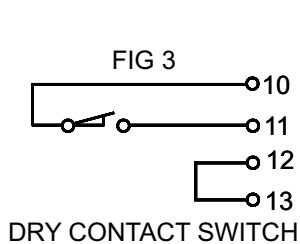
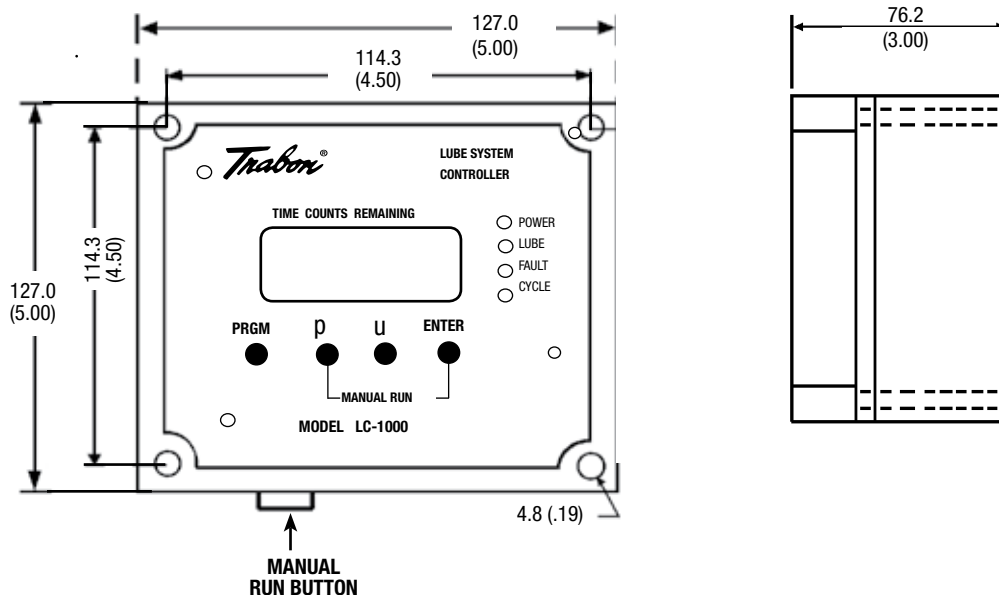

Figure 3, 4 and 5 refer to machine count input only.



DIMENSIONS mm / (Inches)



ORDERING INFORMATION		
Description	Part No.	Old Part No.
LC-1000 Controller (Voltage)		
12 VDC	562876	163-400-050
24 VDC	562877	163-400-051
115 VAC, 50/60 Hz	562878	163-400-052
230 VAC, 50/60 Hz	562879	163-400-053
Replacement Board (Voltage)		
12 VDC	558050	572-144-644
24 VDC	558051	572-144-645
115 VAC, 50/60 Hz	558052	572-144-646
230 VAC, 50/60 Hz	558053	572-144-647

PUSH BUTTONS:

There are four mini push buttons;

PRGM - Initiate Program mode, or alternate between settings for:

- ON (Monitor Time)
- OFF (Pause Time)
- CYCLE (Switch Transitions)
- PUMP (Pulsed On Time)

p - Increase digit

u - Next digit select

ENTER - Enter (save) new setting and advance to next program step.

PROGRAMMING INSTRUCTIONS

The LC-1000 Controller has icons in the display to indicate if the unit is in a lube ON cycle or OFF cycle and to show the timing mode. They are also used to indicate which counter is being adjusted when programming new parameters. The LCD four digit display is used to show the remaining time left in either an ON or OFF cycle, as indicated by the icons. Timing can be done in seconds, minutes, hours or counts. **A flashing LCD character indicates that the timer is in the Programming mode.**

OPERATION

When power is applied, the green "POWER LED" lights and the LC-1000 counts down alternately from the programmed "OFF/ON" Times/Counts to zero.

In the "ON" (Monitor) mode, the "PUMP LED" lights. The pump is activated and both the "ON" and "RUN" icons are displayed. If the programmed number of cycle switch transitions (1/2 cycles) are received before expiration of the "ON" (Monitor) period, the PUMP OUTPUT, "PUMP" LED, "ON" and "RUN" icons turn off and the "OFF" icon will display. If the programmed number of cycle switch transitions (1/2 cycles) are not received before expiration of the "ON" (Monitor) period, a "FAULT" will be registered. This suspends pump operation, turns off the "PUMP" LED, the "ON" and "RUN" icons, turns on the red "FAULT" LED and closes the fault output contacts.

If a pulsed output to the pump is required, a "PUMP ON" time may be programmed from 0 to 99 seconds. Setting this value to zero will provide a steady state output. "PUMP OFF" is fixed at 3 seconds.

The "RUN" icon will display anytime the pump output is energized. During pulsed pump operation, the "RUN" icon will flash on and off in sequence with the pump. During continuous running, the "RUN" icon will not flash.

The Controller is programmed to retain the Time/Count in memory when power is turned off. This feature prevents excessive lubrication in start/stop applications and retains information for cycle to be completed when power is restored.

CHANGING SETTINGS

From the Timer display mode, pressing the "PRGM" button will allow you to review or change between the set "ON" (Monitor), "OFF", "CYCLE", "PUMP" (Pulsed On Time) and "DISPLAY" modes. When in the programming mode, the icons/digits will blink. When in the display mode, the icons/digits do not blink.

1. To set a new "ON" (Monitor) Time/Count, press the "PRGM" key until the "ON" icon blinks. The current "ON" (Monitor) Time/Count will be displayed.
 - a. Press the "ENTER" key. The "ON" (Monitor) Timer/Count digit will blink
 - b. Change the value using the "p" key and the "u" key
 - c. Press the "ENTER" key to accept the new value. The "SEC/MIN/HR/CNT" icon will blink
 - d. Press "ENTER" to accept the time base or the "p" key to scroll through the timing choices
 - e. Press "ENTER" to complete the process

Note: Monitor period is normally set 2 times the actual time required for the pump to satisfy the system cycle requirements

2. The "OFF" icon will now be blinking
 - a. Repeat above process until all "OFF" options have been programmed
 - b. Press "ENTER" to accept the new values
3. The "CYCLE" icon will now be blinking
 - a. Press "ENTER" and the cycle value (1/2 cycles) will blink
 - b. Using the "p" and "u" keys, set the cycle value as follows:
 - Series Progressive: 02 (1 divider cycle), 04 (2 divider cycles), 06 (3 divider cycles), etc.
 - Dual Line: 01 (half cycle), 02 (full cycle)
 - Piston Distributor or Injector: 01
 - c. Press "ENTER" to register the new value
4. The "PUMP" icon will now blink
 - a. Press "ENTER" again and the pump pulsed "ON" time will blink
 - b. Using the "p" and "u" keys, set the value (seconds) as follows:
 - Self-Cycling Pump (Motor Driven or Reciprocating Barrel): 00
 - Single Shot Pump (Piston Distributor or Injector): 00
 - Single Shot Pump (Recycle for Series Progressive): 03 to 10
 - c. Press "ENTER" to accept the new values

Note: In the Recycle mode, PUMP "OFF" time is fixed at 3 seconds. Press "ENTER" to register the new value and return to the "DISPLAY" mode. Scrolling through the modes using the "PRGM" key only will allow the review of the current settings without changing any of the values or timing. It is recommended that programming not be attempted while a lube cycle is in process. After making any change in settings, activate a manual run to initiate the change. Programming examples for specific types of systems are shown on pages 5-7.

MANUAL RUN/RESET

A manual-run lubrication cycle may be initiated by pressing the manual run button, located on the left underside of the unit, or by shorting terminals 14 and 15 together, such as with a remote push-button momentary switch. Manual run may also be initiated by pressing "p" and "ENTER" keys together. Manual run is also used to reset the controller and to clear faults.

Sample LC-1000 Program for Series Progressive,

31 Point Series Progressive System

DESCRIPTION

- System Lube Volume: 6.0 cu in (99 cc) per hour
- AL-50 Pump Used: .24 cu in per stroke (3.9 cc)
- Master Divider Volume per Cycle: .15 cu in (2.4 cc)
- Cycle Interval 15 Minute (1/4 hour) Used
- Volume per Lube Cycle: $6.0 \text{ cu in} / 4 = 1.5 \text{ cu in} / 15 \text{ min.}$
- Master Divider Cycles/Lube Cycle: $1.5 \text{ cu in} / .15 \text{ cu in} = 10 \text{ cycles}$
- Cycle Switch Transitions (2 transitions/cycle) x 10 = 20
- Pump Strokes per Lube Cycle: $1.5 \text{ cu in} / .24 \text{ cu in} = 6.3$ (use 7)
- Monitor Time: 7 Strokes x 6 seconds/stroke (3 second "ON", 3 second "OFF") = 42 second x 2 (safety factor) = 84 seconds.

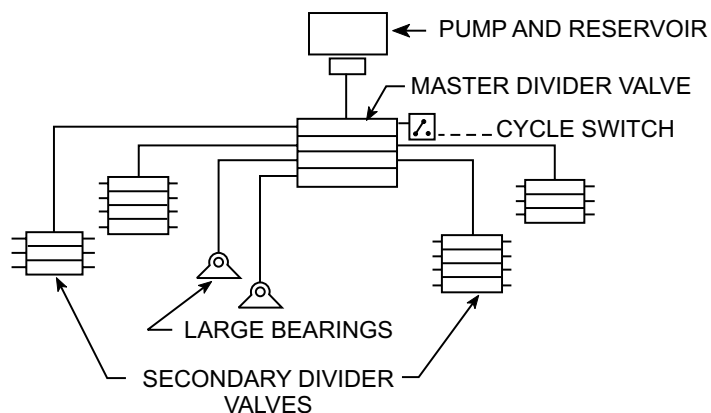

PROGRAMMING

1. Initiate Programming Mode
 - a. Press "PRGM" - "ON" icon blinks
2. "ON" (Monitor Period)
 - a. Press "ENTER" - "ON TIME/COUNT" blinks
 - b. Use "p" and "u" keys to set "ON" (Monitor Time) to 0084
 - c. Press "ENTER" to accept value, "SEC/MIN/HR/CNT" blinks
 - d. Use "p" key to scroll through choices, select "SEC"
 - e. Press "ENTER" to accept choice, "OFF" icon blinks
3. "OFF" (Pause Time)
 - a. Press "ENTER" - "OFF TIME/COUNT" blinks
 - b. Use "p" and "u" keys to set "OFF TIME" to 0015
 - c. Press "ENTER" to accept value, "SEC/MIN/HR/CNT" blinks
 - d. Use "p" key to scroll through choices, select "MIN"
 - e. Press "ENTER" to accept choice, "CYCLE" icon blinks
4. "CYCLE" (Cycle Switch Transitions)
 - a. Press "Enter", "CYCLE" blinks
 - b. Use "p" and "u" keys to select 20 (20 cycle switch transitions = 10 divider cycles)
 - c. Press "ENTER" to accept value, "PUMP" icon blinks
5. "PUMP ON" (Pump Duty-Pulsed/Non-Pulsed)
 - a. Press "ENTER" - "PUMP" (pulsed on time) blinks
 - b. Use "p" and "u" keys to set "ON TIME" to 0.03 (3 sec pulsed output)
 - c. Press "ENTER" to accept value, LCD returns to "DISPLAY" mode

NOTE: If an electrical motor driven pump or self cycling barrel pump is used, enter "00" in Step 5b for non-pulsed output.

Programming is now complete. To verify lube sequence, initiate a manual lube cycle by pressing "MANUAL RUN" button.

Sample LC-1000 Program for Piston Distributor or Injector Systems

31 Point Piston Distributor System

DESCRIPTION

- System Lube Volume: 99 cc (6.0 cu in) per hour
- E0-3 Motor Driven Pump: 140 cc/min (8.5 cu in)
- Total Piston Distributor Displacement: 4.62 cc/cycle (.28 cu in)
- Cycle Interval: 99 cc / 4.62 cc = 21.4 cycles/hr
- 60 min/21.4 cyc = 2.8 min (168 sec) per cycle
- Cycle Switch (Pressure Switch) Transitions: (1 transition/cycle) x 1 = 1
- Pump Run Time: 4.62cc/140cc = .033min (1.98 second)
- Monitor Time: 1.98 sec x 2 (safety factor) = 3.96 seconds

Note: Due to the very short calculated pump run time, use a 20 second monitor time.

PROGRAMMING

1. Initiate Programming Mode
 - a. Press "PRGM" Key – "ON" Icon blinks
2. "ON" (Monitor Period)
 - a. Press "ENTER" Key – ON TIME/COUNT blinks
 - b. Use p Key and u Key to set Monitor ("ON") Time to 0020
 - c. Press "ENTER" Key to accept value; "SEC/MIN/HR/CNT" blinks
 - d. Use p Key to scroll through choices; select "SEC"
 - e. Press "ENTER" Key to accept choice; "OFF" Icon blinks
3. "OFF" (Pause Time)
 - a. Press "ENTER" Key – OFF TIME/COUNT blinks
 - b. Use p Key and u Key to set "OFF TIME" to 0168
 - c. Press "ENTER" Key to accept value; "SEC/MIN/HR/CNT" blinks
4. "CYCLE" (Pressure Switch Transitions)
 - a. Use p Key to scroll through choices; select "SEC"
 - e. Press "ENTER" Key to accept choice; "CYCLE" Icon blinks
5. "PUMP ON" (Pump Duty-Pulsed/Non-Pulsed)
 - a. Press "ENTER" Key; "PUMP" (pulsed on time) blinks
 - b. Use p Key and u Key to set "ON TIME" TO 00 (non-pulsed output)
 - c. Press "ENTER" Key to accept value; LCD returns to "DISPLAY" mode

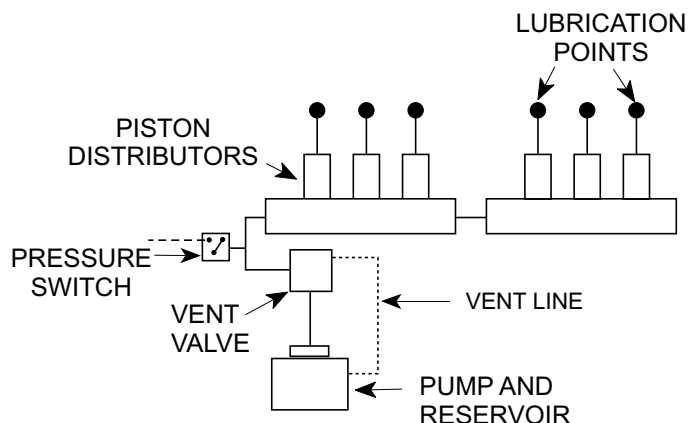

Programming is now complete. To verify lube sequence, initiate a manual lube cycle by pressing "Manual Run" button.

Sample LC-1000 Program for Bi-Flo (Dual Line) Systems

31 Point Bi-Flo (Dual Line) System

DESCRIPTION

- System Lube Volume: 6.0 cu in (99 cc) per hour
- Bi-Flo Motor Driven Pump Used: 8.6 cu in (141 cc) per minute.
Note 1: Requires a Motor Starter
Note 2: Requires a hydraulic reverser with cycle switch.
- Cycle Interval 15 Minute (1/4 hour) Used
- Volume per Lube Cycle: $6.0 \text{ cu in} / 4 = 1.5 \text{ cu in} / 15 \text{ minute}$.
- Cycle Switch Transitions (2 transitions/cycle) x 1 = 2
- Pump Run Time per Lube Cycle: $1.5 \text{ cu in} / 8.6 \text{ cu in} = .17 \text{ min}$ (10.4 second)
- Monitor Time: $10.4 \text{ sec} \times 2$ (safety factor) = 20.8 second (use 21 second).

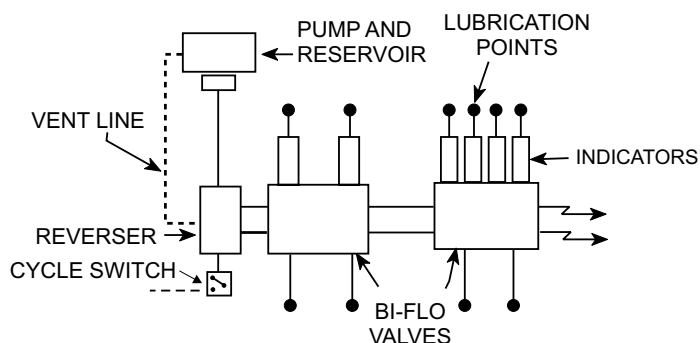

PROGRAMMING

1. Initiate Programming Mode
 - a. Press "PRGM" Key – "ON" Icon blinks
2. "ON" (Monitor Period)
 - a. Press "ENTER" Key – ON TIME/COUNT blinks
 - b. Use p Key and u Key to set Monitor ("ON") Time to 0021
 - c. Press "ENTER" Key to accept value; "SEC/MIN/HR/CNT" blinks
 - d. Use p Key to scroll through choices; select "SEC"
 - e. Press "ENTER" Key to accept choice; "OFF" Icon blinks
3. "OFF" (Pause Time)
 - a. Press "ENTER" Key – OFF TIME/COUNT blinks
 - b. Use p Key and u Key to set "OFF TIME" to 0015
 - c. Press "ENTER" Key to accept value; "SEC/MIN/HR/CNT" blinks
 - d. Use p Key to scroll through choices; select "MIN"
 - e. Press "ENTER" Key to accept choice; "CYCLE" Icon blinks
4. "CYCLE" (Cycle Switch Transitions)
 - a. Press "ENTER" Key; CYCLE (switch transitions) blinks
 - b. Use p Key and u Key to select 02 (02 cycle switch transitions = 1 System cycle)
 - c. Press "ENTER" Key to accept value; "PUMP" Icon blinks
5. "PUMP ON" (Pump Duty-Pulsed/Non-Pulsed)
 - a. Press "ENTER" Key "PUMP" (pulsed on time) blinks
 - b. Use p Key and u Key to set "ON TIME" TO 00 (Non-pulsed output)
 - c. Press "ENTER" Key to accept value; LCD returns to "DISPLAY" mode

Programming is now complete. To verify lube sequence, initiate a manual lube cycle by pressing "MANUAL RUN" button.

NOTE 1: If half cycle Bi-Flo (Dual Line) operation is desired, select 01 (one switch transition) in step 4b.

NOTE 2: If a single cycle pump is used in conjunction with a Bi-Flo Reverser, enter "03" in Step 5b for pulsed pump output (3 second "ON", 3 second "OFF").

Your Program Record

Company: _____ By: _____

Machine Identification: _____ Date: _____

System Type: Bi-Flo ___ Piston Distributor ___ Series ___ Other: _____

On (Monitor) Value: Time/Count _____ Seconds ___ Minutes ___ Hours ___ Counts _____

Off Value: Time/Count _____ Seconds ___ Minutes ___ Hours ___ Counts _____

Cycle Value (Switch Transitions): _____

Pump On (Pulsed/Non Pulsed): _____ (00 is Non-Pulsed)

TROUBLESHOOTING

Symptom	Cause	Remedy
Blank Display, No LEDs	No Power	Check Wiring & Fuse-Repair as Required
	Bad Circuit Board	Replace Circuit Board
No Display or Black Display, but System Operates	Temperature too High or too Low	Move Controller to Location that is within Temperature Limits
	Bad Display	Replace Circuit Board
Program Will Not Run	Programming Error or Bad Circuit Board	Review Instructions & Examples-Reprogram/ Replace Circuit Board as Required
	In Programming Mode	Exit by Pressing PRGM
Can't Change Program	Programming Error or Bad Circuit Board	Review Instructions & Examples-Reprogram/ Replace Circuit Board as Required
	Power Off Before Programming Completed	Complete the Programming Process Before Removing Power
Fault Light On	No Cycle Input	Check Cycle Switch & Wiring-Repair as Required
	Level Sw. or HP Sw. Closed (If Used)	Check Reservoir Level and Operating Pressure-Refill/Repair as Required
	System Blockage	Correct Blockage (see Bul 30101)
	No Pump Flow or Low Flow	Check Reservoir Level & Pump Output-Refill/Repair as Required
	Main Line Leaks	Check & Repair as Required
	Plugged Filter/Strainer	Clean or Repair as Required
Failure to Indicate a Fault	Monitor Time too Short	Increase Monitor Time
	Cycle Count Set to 00	Set Cycle Count to Desired Number of Half-Cycles.
	Programmed Machine Count Mode, and Wire According to Fig. 1	Program On and Off in Time Mode, or Wire per Fig. 2.

Contact us today!

To receive product information or talk with a Graco representative, call 800-533-9655 or visit us online at www.graco.com.

