



Injecto-Flo EO-3 Electric Operated Pumps

DESCRIPTION

The EO-3 pump package includes a 115 or 230 VAC motor direct coupled to a gear pump and mounted on a 3.6 liter (7.6 pint) plastic reservoir. Each is equipped with a low level switch and rated for service up to 24 bar (350 psi). Timer equipped models include a built in pressure switch. On/off cycles on remote control models are programmed by a remote timer or from a machine's PLC where available.

When electrical power is applied to the pump motor, lubricant flow pressurizes the system mainlines causing the piston distributors to dispense a measured volume of lubricant to the bearing points. Making of the pressure switch contacts (pressure switch equipped models) or expiration of the on time causes power to be shut off from the motor. This stops flow and permits the internal vent valve to release mainline pressure which allows the piston distributors to re-prime in preparation for the next lube cycle.



SPECIFICATION	
Motor Voltage	115 ± 10% VAC, 50/60 Hz, 1 pH 230 ± 10% VAC, 50-60 Hz, 1 pH
Current Consumption	3.8A in-rush, 1.8A running @ 115 VAC 1.9A in-rush, 0.9A running @ 230 VAC
Motor Power	1/18 hp
Motor Speed	1680 RPM @ 60 Hz 1340 RPM @ 50 Hz
Pump Flow Rate	8.5 in ³ /min (140 cm ³ /min)
Pressure	Relief valve protected, 350 psi (24 bar), Pressure switch set @ 320 psi (22 bar)
Oil Viscosity	ISO 50-1500 (SUS 250-5000)
Operating Temperature	14°F to 120°F (-10°C to 49°C)
Operation	Intermittent, 20% duty cycle @ max pressure (350 psi)
*Low Level Switch	10 watt @ 115/230 VAC 5 watt @ 24 VDC, N.C. Contacts
Suction Strainer	60 mesh screen
Pressure Gauge	0-850 psi (0-60 bar)
Electrical Connection	Supplied with liquid tight cable connector and screw terminals
Reservoir	7.6 pint (3.6 liter) translucent nylon
Timer Equipped Models	
Timer	
On-Time	5-90 sec
Off-Time	2.5-1000 min or 1-21 hours (pre-lube- selectable)

Pressure Monitor-Selectable	320 psi (22 bar)
Programming	Via 2 Jumper Bars and 8 Dip Switches
One Fault Output	SPDT
Three Indicator Lights	Power on (GN), Operating (YL), Fault (Rd)
Manual Run	Push-button

ORDERING INFORMATION		
Description	Part No.	Old Part No.
115V, timer, manual run, indicator light, pressure switch, low level switch	562850	126-410-017
230V, timer, manual run, indicator light, pressure switch, low level switch	247653	126-410-018
115V, remote, manual run, pressure switch, low level switch	562851	126-410-021
Description	Part No.	Old Part No.
230V, remote, manual run, pressure switch, low level switch	247669	126-410-026
Replacement Outlet Nut, 6 mm tube	555732	435-702-466
Replacement Outlet Ferrule, 6 mm tube	555731	435-702-421
Outlet Adaptor, M12 x 1M) to 1/4 NPTF(F)	Dis	435-702-471

INSTALLATION DATA

Mounting

The entire pump package is installed with two 6mm (1/4 in) screws that pass through holes in the mounting flange at the top of the reservoir. Mounting dimensions are given in Figure 1. Figure 2 is a simplified schematic for the entire pumping unit.

DIMENSIONS [mm/(inches)]

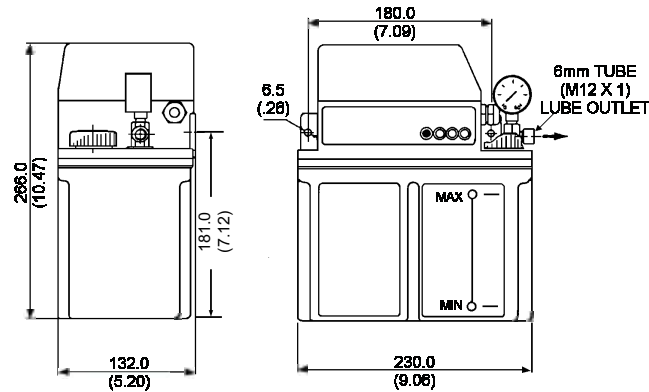

Figure 1

Remote Control

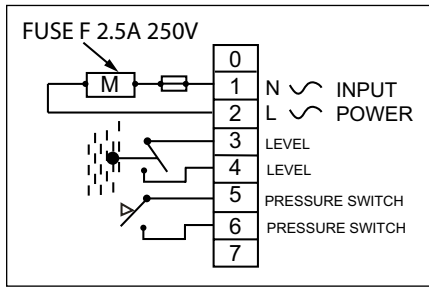

Figure 3

Time Control

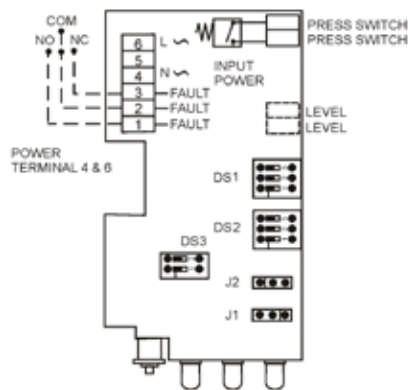

Figure 4

System Schematic

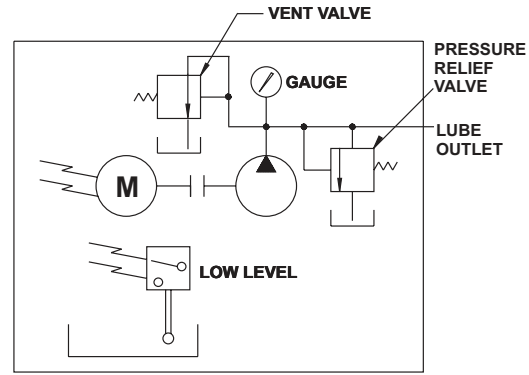

Figure 2

Electrical Hookup

Electrical hookups are shown in Figures 3 and 4. Timer dip switch settings and jumper bar connections (timer equipped models) are shown in Figure 5. All electrical connections should be made with 16 AWG stranded wire and insulation rated for 115/230 VAC and 105°C.

TIMER DIP SWITCH SETTINGS AND JUMPER BAR CONNECTIONS

DIP - SWITCH DS3	DIP - SWITCH DS3	DIP - SWITCH DS3	DIP - SWITCH DS3	DIP - SWITCH DS2
DIP - SWITCH DS1 PAUSE TIME VALUES IN MINUTES	DIP - SWITCH DS1 PAUSE TIME VALUES IN MINUTES	DIP - SWITCH DS1 PAUSE TIME VALUES IN MINUTES	DIP - SWITCH DS1 PAUSE TIME VALUES IN HOURS	DIP - SWITCH DS2 WORKING TIME VALUES IN SECONDS
5	2.5	20	1	5
10	3	40	3	10
15	5	60	6	15
20	7	80	9	20
40	10	160	12	30
80	20	320	15	40
160	40	640	18	60
250	80	1000	21	90

"PRELUBE - REQUIRED" / "PRELUBE - NOT REQUIRED" JUMPER J1

TO HAVE PRELUBE OR NOT THE JUMPER NEEDS TO BE CONNECTED AS SHOWN

YES

NO

MAINLINE PRESSURE BUILD UP MONITORED OR NOT MONITORED JUMPER J2

NOT MONITORED

PRESSURE MONITORED

WITH PRESSURE MONITORING SELECTED, IF PRESSURE SWITCH DOES NOT MAKE DURING THE PROGRAMMED PUMP WORK TIME, A FAULT WILL BE INDICATED AND THE PUMP WILL SHUT DOWN

Figure 5

All written and visual data contained in this document are based on the latest product information available at the time of publication. Graco reserves the right to make changes at any time without notice.

Contact us today!

To receive product information or talk with a Graco representative, call 800-533-9655 or visit us online at www.graco.com.

